

**FECHOS CENTRAIS
CIERRES CENTRALES
CENTRAL BOLTS
FERMETURES CENTRALES**



• **MATERIAIS**

Manípulos: alumínio
Perno: aço inox
Tecla: plástico rígido

• **MATERIALES**

Cuerpo: aluminio
Eje: acero inoxidable
Boton: plástico rígido

• **MATERIALS**

Base: aluminium
Pin: stainless steel
Button: strong nylon

• **MATÉRIAUX**

Base: aluminium
Tige: inox
Bouton: nylon solide

DIN4366

Fecho de teclas.
Cierre central.
Central bolt.
Fermeture centrale.

DIN4366 C/ CH/ CYL

Fecho de teclas com chave. Bloqueamento da tecla por rotação da chave a 180°.
Cierre central con llave. Bloqueo por rotación de la llave 180°.
Central bolt with cylinder. Locking by turning the key 180°.
Fermeture central à cylindre. Condamnation par rotation de la clé a 180°.



DIN4366

REF.	A/B POSIÇÃO ABERTO POSICIÓN ABIERTO OPEN POSITION POSITION D'OUVERTURE
DIN4366.21	21
DIN4366.24	24
DIN4366.26	26
DIN4366.30	30
DIN4366.32	32
DIN4366.36	36
DIN4366.42	42

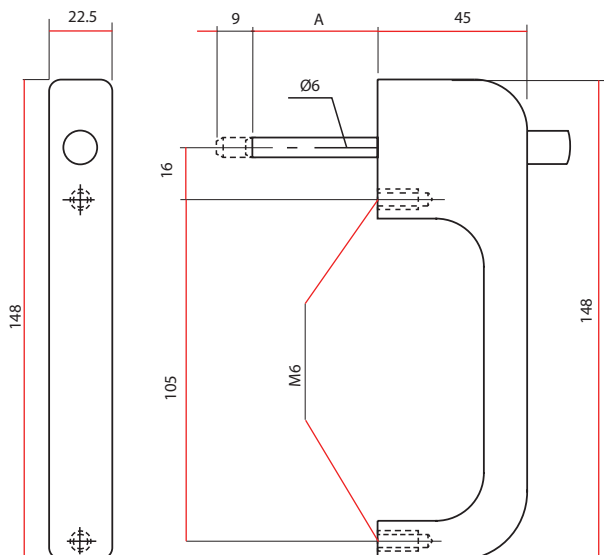

DIN4366

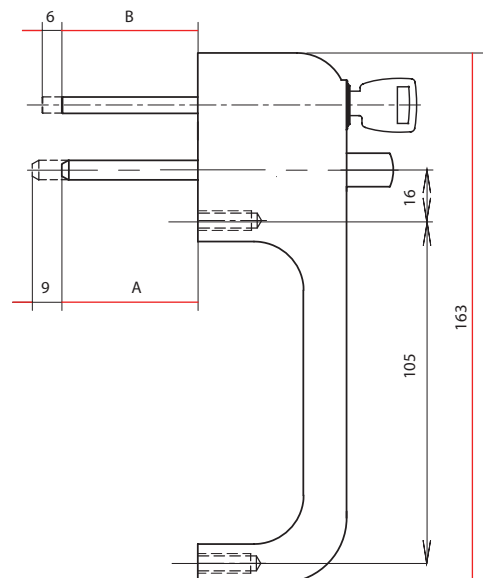

DIN4366 C/CH