

FECHADURAS



ALAVANCA



SUMÁRIO ICONES

ICONES
ICONOS
ICONS
ICÔNES

EMBALAGENS - ENVASES - PACKAGING - EMBALLAGES

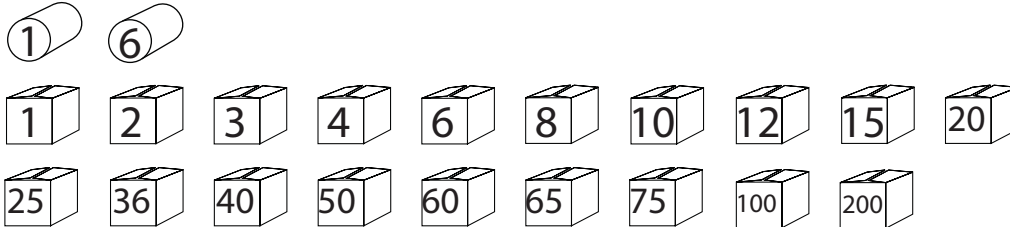

MATERIAIS - MATERIALES - MATERIALS - MATÉRIELS



ACABAMENTOS - ACABADOS - FINISHINGS - FINITIONS



CORES - COLORES - COLOURS - COLEURS



COR POR ENCOMENDA - COLOR POR ENCARGO - COLOR BY REQUEST - COLEUR PAR COMMANDE

Refs. 6200 mate (verde 61) - 6192 (verde 62) - 6005 - 6005 (mate) - 6009

Refs. 1013 - 1015 - 1015(mate)

Refs. 8014 - 8017 - 8146 - 8146 (mate)

Refs. 7011 - 7012 - 7035 (mate) - 7040 - 7042 - 7048 - 9002 - 9006

Refs. 9001 - 9003 - 9010 - 9110 (mate)

Refs. 3003 - 3005

Refs. 5010 - 5013

Refs. 1011



SUMÁRIO ICONES

ICONES
ICONOS
ICONS
ICÒNES

MEDIDAS - MEDIDAS - SIZES - MESURES



- Distância do meio do cilindro à frente da fechadura.
- Distancia desde el medio del cilindro al frente de la cerradura.
- Distance from the middle of the cylinder to the lock front plate.
- Distance à du milieu du cylindre jusqu'au têtierre.



- Distância do meio do quadrado até o centro do cilindro.
- Distancia desde el medio del cuadradillo hasta el centro del cilindro.
- Distance from the middle of the square to the middle of cylinder.
- Distance du milieu du carré jusqu'au milieu du cylindre.



- Testa lisa / testa U
- Frente plano / frente U
- Flat shape / U shape
- Têtierre plate / têtierre u

REGULAÇÃO - REGULACIÓN - REGULATION - RÉGLAGE



CONCEITOS - CONCEPTOS - CONCEPTS - CONCEPTS

Instalação rápida da dobradiça no perfil - Instalación rápida de la bisagra en el canal Easy installation in the profiles - Instalation facile de la paumelle dans le profil

Caixas estreitas para perfis de corte térmico - Cajas estrechas para perfiles de corte térmico Narrow boxes for thermal break profiles - Boîtes étroites pour profilés à rupture thermique

Flexibilidade/ facilidade na permuta de trinco para rolete ou viceversa Flexibilidad / facilidad en la permuta del picaporte para rodillo y viceversa Flexibility / facility on the the swap latch to the roller and vice versa Flexibilité / facilité au chagement antre demi-tour et rouleau

As imagens contidas neste catálogo, destinam-se à promoção dos produtos e fruto do seu constante desenvolvimento, podem não reflectir a forma como num dado momento, um produto é fornecido ou embalado, pelo que por si não constituem uma obrigação legal. Antes de cada encomenda é sempre necessário confirmar o seu estado actual.

Las imágenes mostradas en este catálogo se destinan a la promoción de sus productos y fruto de su constante desarrollo pueden no reflejar la forma en como en un momento dado, el producto puede ser distribuido o embalado, de modo que por si, no constituyen una obligación legal. Antes de cada pedido será necesario confirmar su estado actual.

The images in this catalogue are intended to promote the product and by its constant development, may not reflect the way a product is being delivered or packaged, so by themselves they do not constitute a legal obligation. Before each order it is always necessary to confirm its current status.

Les images de ce catalogue se destinent à la promotion des produits et elles ne constituent pas une obligation contractuelle de la façon dont les produits sont finalement fabriqués, emballés ou vendus. Avant une commande ils faut toujours vérifier sont stade actuelle.

FECHADURA DE ALAVANCA 3 PONTOS

CERRADURA DE PALANCA 3 PUNTOS 3
POINTS HANDLE ACTION LOCK SERRURES
RELEVAGE 3 POINTS



Fechadura superior com língua em forma de gancho em inox.

Cerradura superior con palanca en forma de gancho em inox.

Top lock with inox hook bolt.

Serrure supérieure à levier en forme de crochet inox.

Fechadura central com trinco reversível e rolete e língua deslizante em zamak.

Cerradura central con picaporte reversible y palanca deslizante en zamak.

Center lock with reversible latch and roller and advancing bolt.

Verrouillage central avec le verrou réversible et levier coulissant en zamak.

Fechadura inferior com língua em forma de gancho em inox.

Cerradura inferior con palanca en forma de gancho em inox.

Down lock with stainless steel hook bolt.

Serrure inférieure à levier en forme de crochet inox.

Fechadura superior com língua em forma de gancho em inox.

Fechadura central com trinco reversível ou rolete e língua deslizante.

Fechadura inferior com língua em forma de gancho inox. Com uma distância entre o cilindro e o puxador de 85mm/92mm.

Com uma altura de 1600mm/ 1850mm/ 2100mm.

Cerradura superior con palanca en forma de gancho em inox.

Cerradura central com picaporte reversible o rodillo y palanca deslizante.

Cerradura inferior con palanca en forma de gancho inox. Distancia entre el cilindro y la manilla de 85mm/92mm. Con una altura de 1600mm/ 1850mm.

Top lock with inox hook bolt.

Center lock with reversible latch or roller and advancing bolt.

Down lock inox hook bolt.

Center distance from the center of the spindle to the center of the cylinder 85mm/92mm.

Lock might 1600mm/ 1850mm.

Levier de verrouillage supérieure accroché inoxydable. Verrouillage central avec le verrou réversible et le levier coulissant.

Levier de verrouillage fond en forme de crochet em inox. Distance entre le cylindre et la poignée 85 mm / 92 mm. Hauteur de 1600mm / 1850mm.



INX

35

45

85

92

16

22

24



FECHADURA DE ALAVANCA CHAPAS TESTA

CERRADURA DE PALANCA CERRADEROS HANDLE
 ACTION LOCK STRIKER PLATES SERRURES
 RELEVAGE GÂCHES

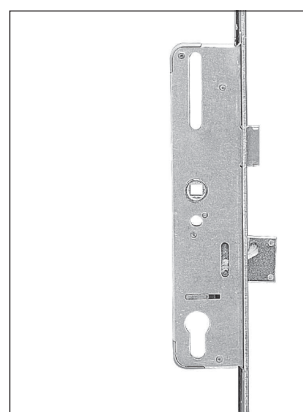
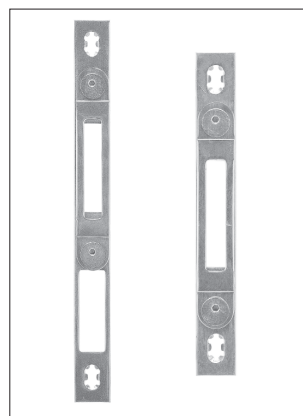
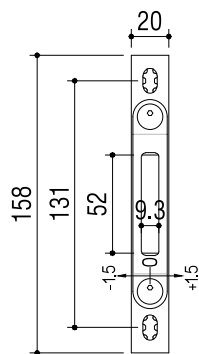
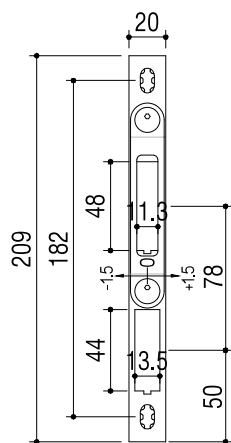
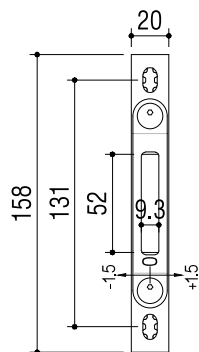

Fechadura em posição de segurança
 Cerradura en posición de seguridad
 Lock in safety position
 Position de sécurité de la verrouillage.

Fechadura em posição livre
 Cerradura en posición libre
 Lock in rest position
 Serrure en position libre.

FECHADURA DE ALAVANCA

CERRADURA DE PALANCA
HANDLE ACTION LOCK
SERRURES RELEVAGE

GANCHO/PALANCA/LEVER/RELEVAGE 3P

REFS.	TESTA FRENTE FRONT GÂCHE	FECHADURA CERRADURA LOCK SERRURE
DIN3510	16	92mm
DIN3511	22	92mm
DIN3512	24	92mm
DIN3550	16	85mm
DIN3551	22	85mm
DIN3552	24	85mm



GANCHO+ROLETOS/PALANCA+ROLETOS/LEVER +ROLLER/RELEVAGE+ ROULEAUX 5P

REFS.	TESTA FRENTE FRONT GÂCHE	FECHADURA CERRADURA LOCK SERRURE
DIN3520	16	92mm
DIN3521	22	92mm
DIN3522	24	92mm
DIN3560	16	85mm
DIN3561	22	85mm
DIN3562	24	85mm



FECHADURA DE ALAVANCA

CERRADURA DE PALANCA
HANDLE ACTION LOCK
SERRURES RELEVAGE

ROLETOS/ROLETOS/ROLLER/ ROULEAUX 5P

REFS.	TESTA FRENTE FRONT GÂCHE	FECHADURA CERRADURA LOCK SERRURE
DIN3530	16	92mm
DIN3531	22	92mm
DIN3532	24	92mm
DIN3570	16	85mm
DIN3571	22	85mm
DIN3572	24	85mm

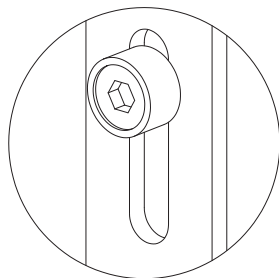

COGUELOS/BULONES/MUSHROOMS/ CHAMPIGNONS 5P

REFS.	TESTA FRENTE FRONT GÂCHE	FECHADURA CERRADURA LOCK SERRURE
DIN3540	16	92mm
DIN3541	22	92mm
DIN3542	24	92mm
DIN3500	16	85mm
DIN3501	22	85mm
DIN3502	24	85mm

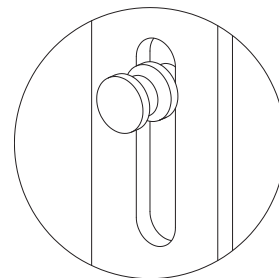

FECHADURA DE ALAVANCA

CERRADURA DE PALANCA
HANDLE ACTION LOCK
SERRURES RELEVAGE

GANCHO/PALANCA/LEVER/RELEVAGE 3P

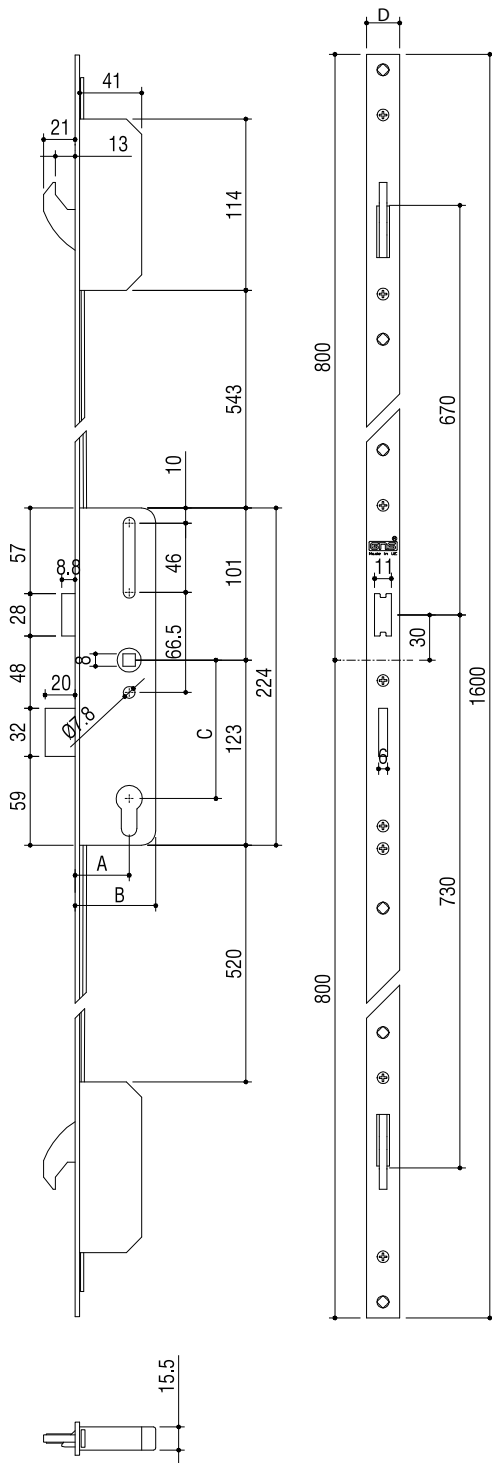

GANCHO+ROLETOS/PALANCA+ROLETOS/LEVER
+ROLLER/RELEVAGE+ ROULEAUX 5P

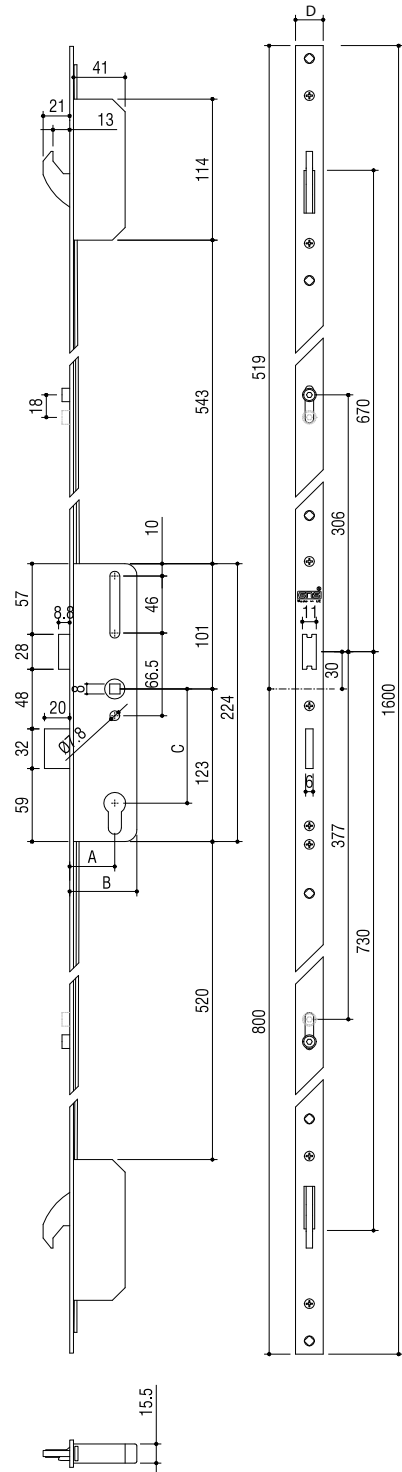

A	B	C	D
35mm	53 mm	85/92 mm	16 / 22 / 24 mm
45mm	63 mm	85/92 mm	16 / 22 / 24 mm

FECHADURA DE ALAVANCA

CERRADURA DE PALANCA
HANDLE ACTION LOCK
SERRURES RELEVAGE

ROLETOS/ROLETOS/ROLLER/ ROULEAUX 5P

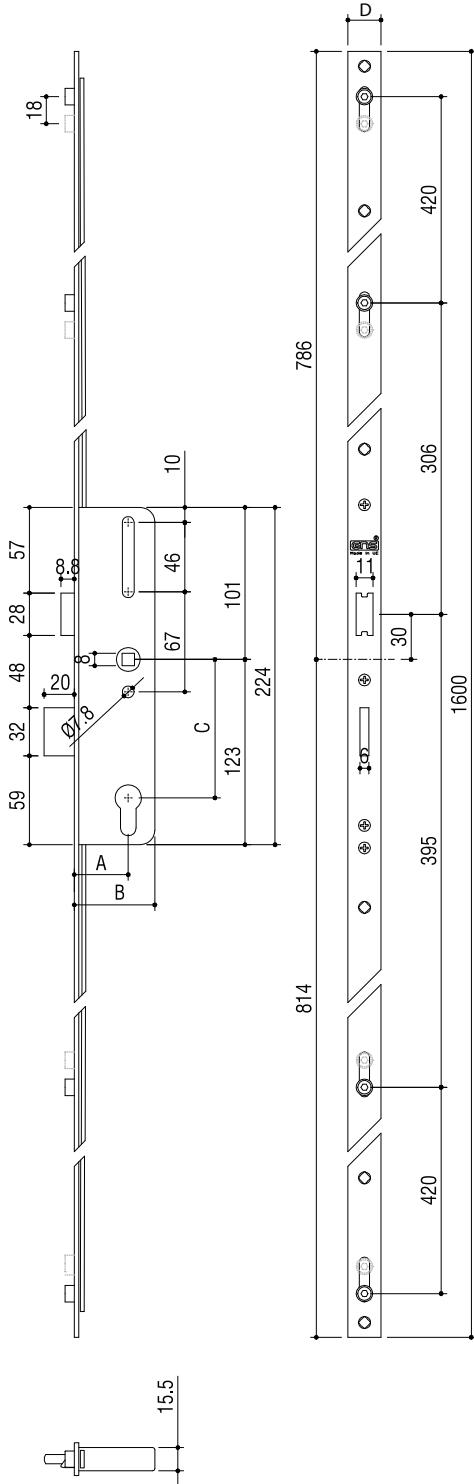

COGUMELOS/BULONES/ MUSHROOMS/
CHAMPIGNONS 5P

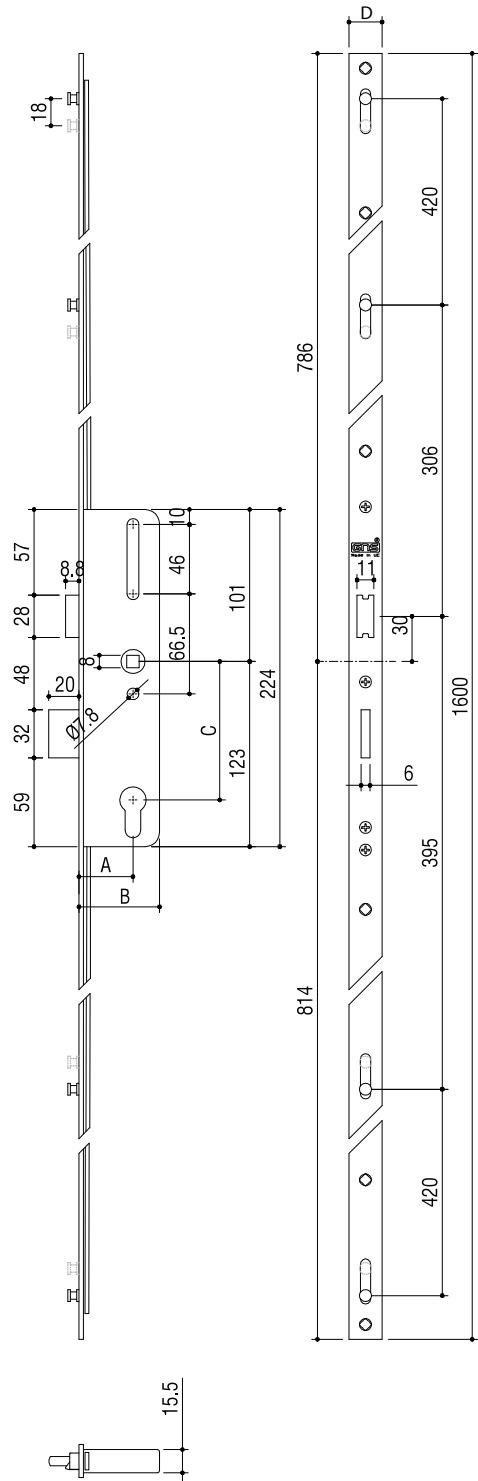

A	B	C	D
35mm	53 mm	85/92 mm	16 / 22 / 24 mm
45mm	63 mm	85/92 mm	16 / 22 / 24 mm



FECHADURA DE ALAVANCA 1 PONTO

CERRADURA DE PALANCA 1 PUNTO 1
 POINT HANDLE ACTION LOCK SERRURE
 RELEVAGE 1 POINT

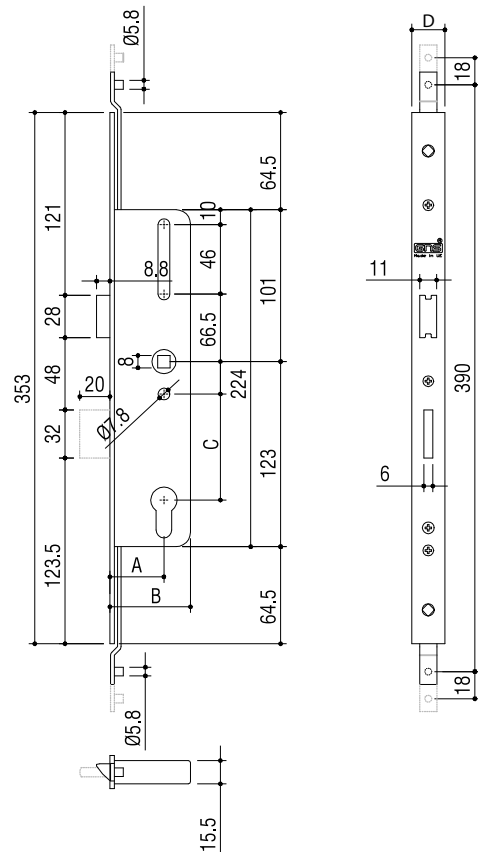

REFS.

DIN3517
 DIN3518
 DIN3519

DIN3546
 DIN3547
 DIN3548

TESTA FRENTE FRONT GÂCHE

16
 22
 24

16
 22
 24

FECHADURA CERRADURA LOCK SERRURE

92mm
 92mm
 92mm

85mm
 85mm
 85mm



INX



A	B	C	D
35mm	53 mm	85/92 mm	16 / 22 / 24 mm
45mm	63 mm	85/92 mm	16 / 22 / 24 mm

FECHADURA DE ALAVANCA MULTIPUNTO

CERRADURA DE PALANCA MULTIPUNTO
MULTIPOINT HANDLE ACTION LOCK SERRURES
RELEVAGE MULTIPOINT

DIN3547 K

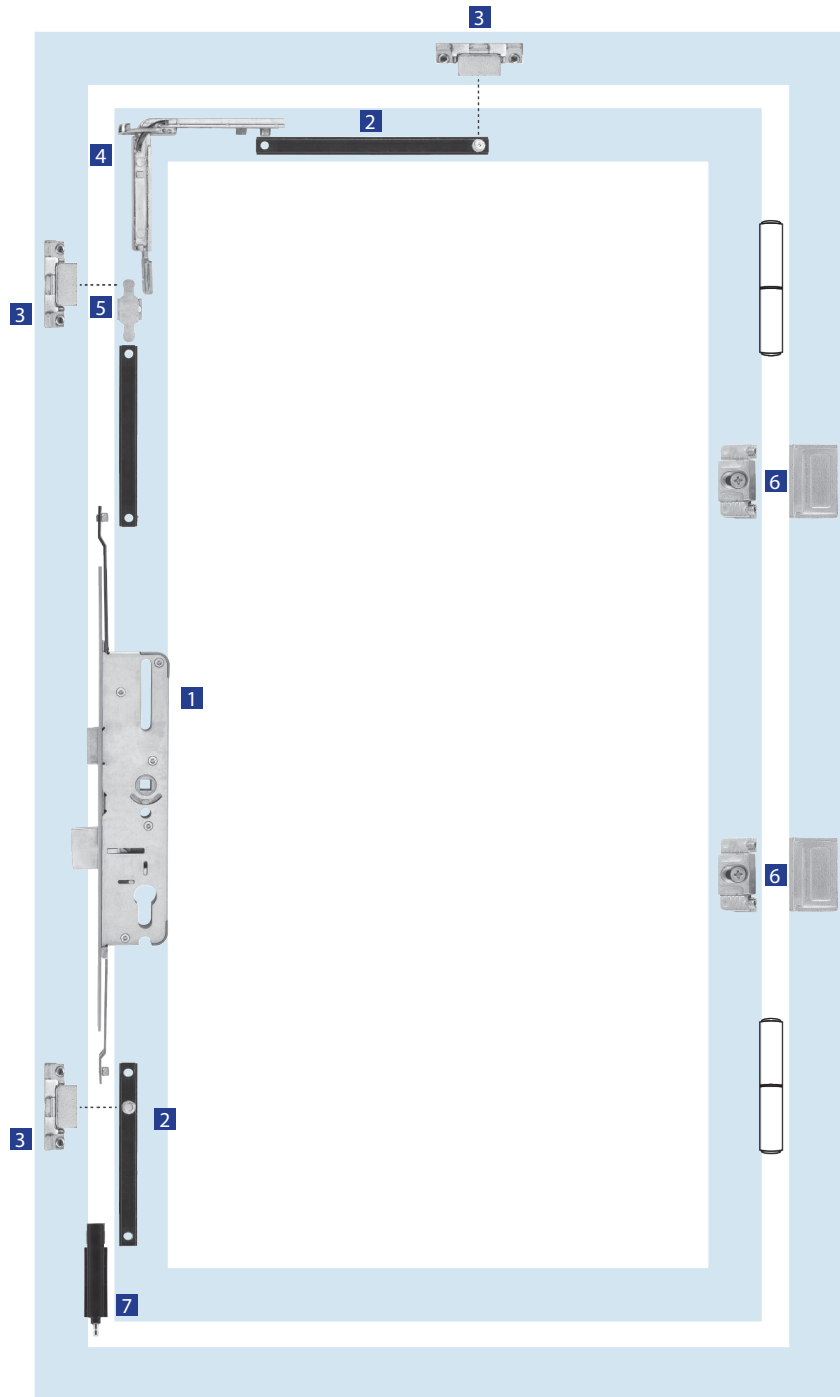

- | | | | |
|------------------------------|----------------------------|------------------------------|---------------------------------|
| 1 Fechadura | 1 Cerradura | 1 Mono point lock | 1 Serrure |
| 2 Barra nylon ou alumínio | 2 Barra nylon o alumínio | 2 Nylon/alu transmission bar | 2 Nylon ou aluminium tige |
| 3 Ponto de fecho OBT025 | 3 Punto de cierre OBT025 | 3 Locking point OBT025 | 3 Point de fermeture OBT025 |
| 4 Esquadro de reenvio | 4 Escuadra de reenvio | 4 Transmission corner | 4 Angle de joue inférieure |
| 5 Ligador OBT023 | 5 Pieza de encajar OBT023 | 5 Connector OBT023 | 5 Connecteur OBT023 |
| 6 Dobradiça oculta ref. 5215 | 6 Bisagra oculta ref. 5215 | 6 Hidden hinge ref. 5215 | 6 Charnière invisible ref. 5215 |
| 7 Ponteira nylon | 7 Puntera nylon | 7 Metal/nylon side lock | 7 Orteil en nylon |



FECHADURA DE ALAVANCA

CERRADURA DE PALANCA
HANDLE ACTION LOCK
SERRURES RELEVAGE

INSTRUÇÕES - INSTRUCCIONES - INSTRUCTIONS - INSTRUCTIONS

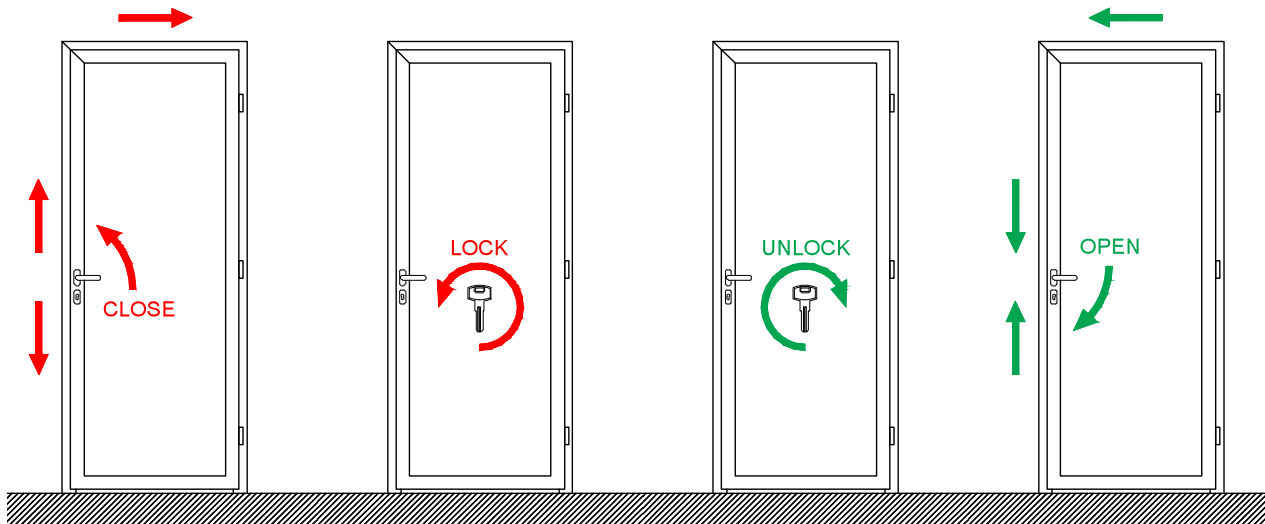

Funcionamento
Funcionamiento
Function
Fonction

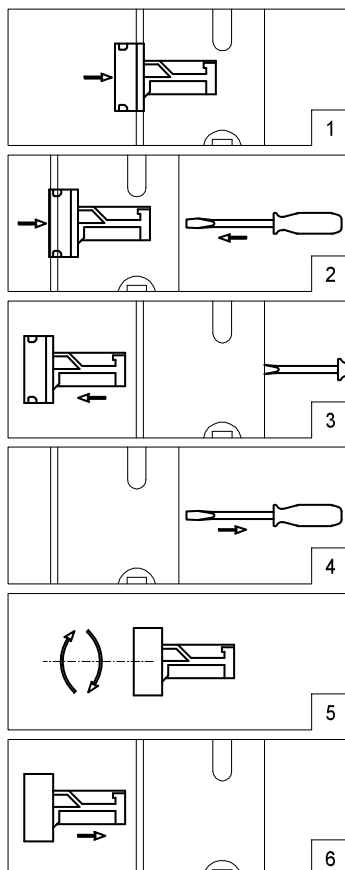

Virar Trinco
Girar Picaporte Palanca
Turn Handle ActionLatch
Tourner le Demi-tour Relevage



DINERU - Sistemas de Alumínio Lda.
Rua Bartolomeu Dias 160
4485 - 482 Mindelo (VCD)
Portugal

Tlf.: +351 252 672 016
Fax: +351 252 672 019
Tlm.: +917 510 646

geral@dineru.com
www.dineru.com